

cgs328-multiplexer.schdoc

R124 - R126 not on PCB

cgs328-power.schdoc

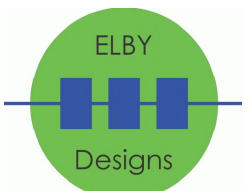

3 Therese Street
Bridport
TAS 7262
Australia

IMPORTANT NOTICE:
Information disclosed by this drawing is the property of ELBY Designs.
Duplication or manufacturing rights granted by written permission only.

CGS328 - Sequential Switch User Interface and Counter

In collaboration with Ken Stone

Size A4	FCSM No. 24/04/2022	DWG No. cgs328-controller.schdoc	Rev V3.0
Scale	Laurie Biddulph		Sheet 1 of 3

1

2

3

4

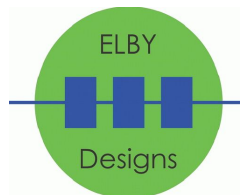
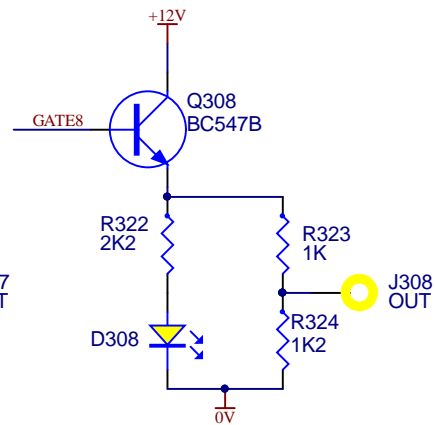
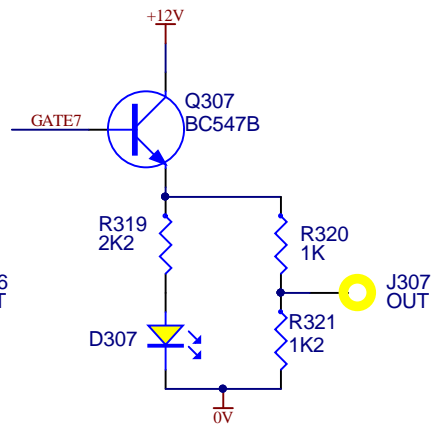
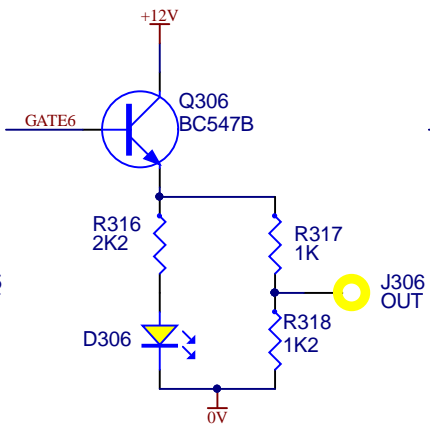
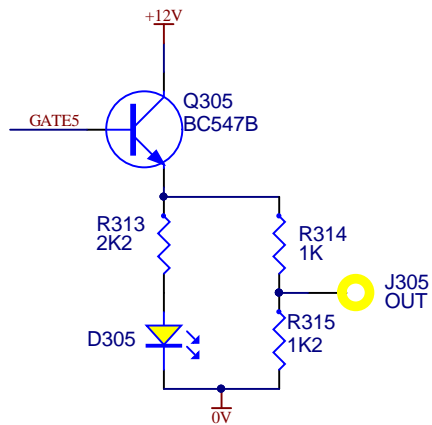
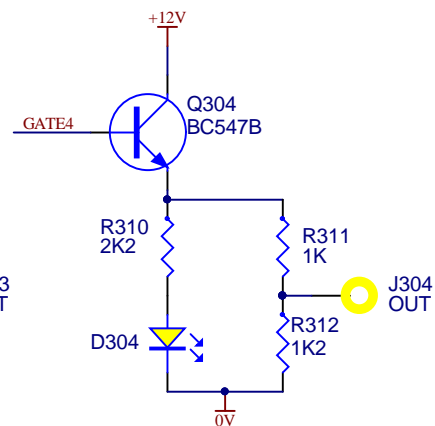
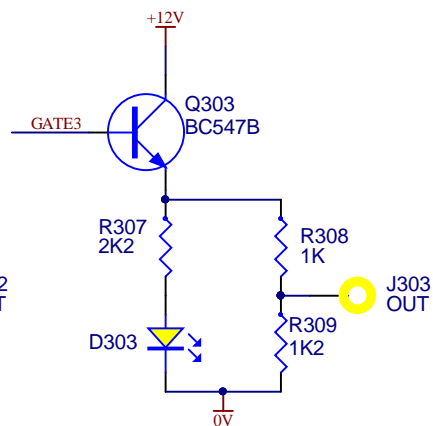
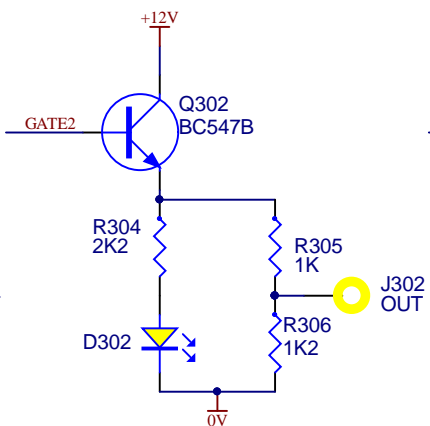
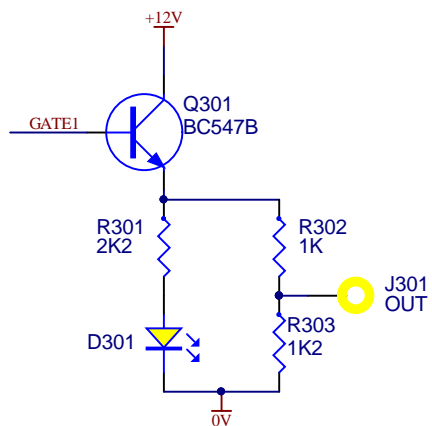

3 Therese Street
Bridport
TAS 7262
Australia

IMPORTANT NOTICE:
Information disclosed by this drawing is the property of ELBY Designs.
Duplication or manufacturing rights granted by written permission only.



CGS328 - Sequential Switch Output Drivers

Size A4	FCSM No. 24/04/2022	DWG No. cgs328-buffers.schdoc	Rev V3.0
Scale	Laurie Biddulph		Sheet 3 of 4

1

2

3

4

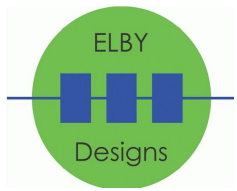
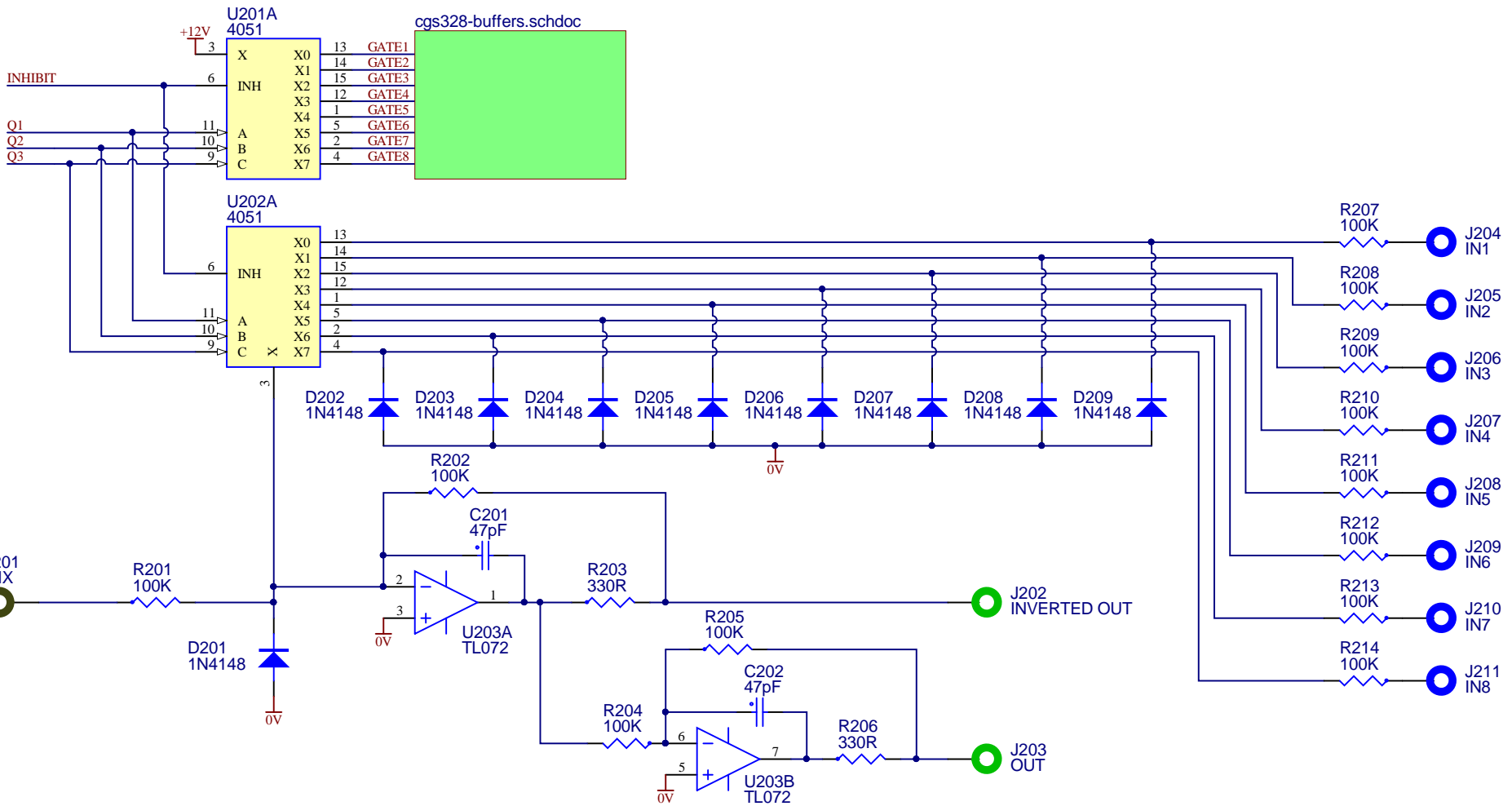

3 Therese Street
Bridport
TAS 7262
Australia

IMPORTANT NOTICE:
Information disclosed by this drawing is the property of ELBY Designs.
Duplication or manufacturing rights granted by written permission only.



CGS328 - Sequential Switch Multiplexer

Size A4	FCSM No. 24/04/2022	DWG No. cgs328-multiplexer.schdoc	Rev V3.0
Scale		Laurie Biddulph	Sheet 4 of 6

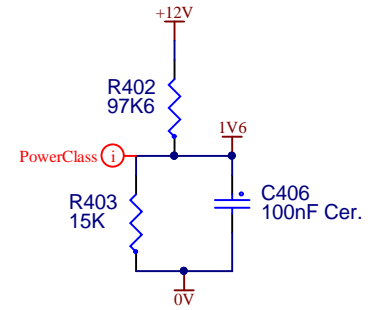
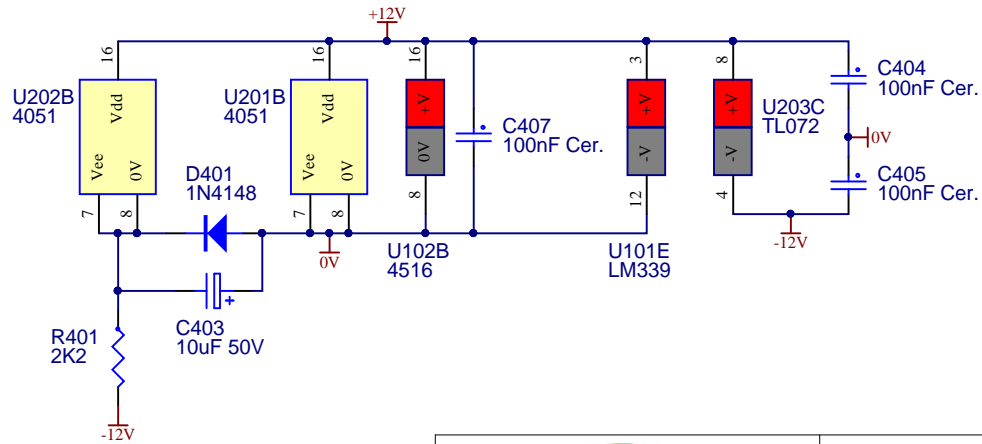
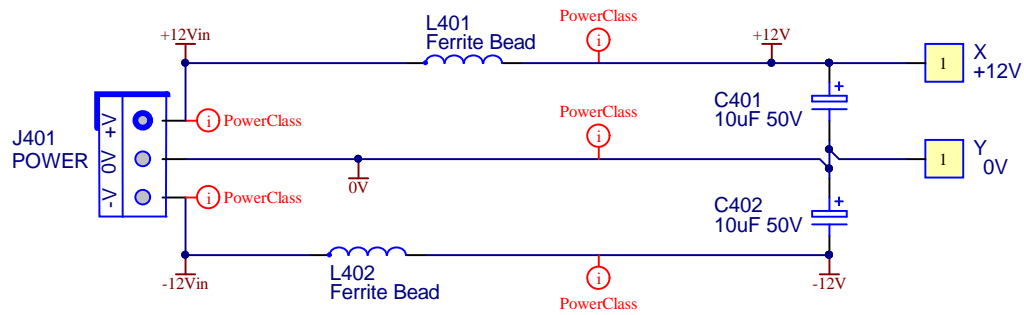

RCM
RoHS
LOGO-CGS

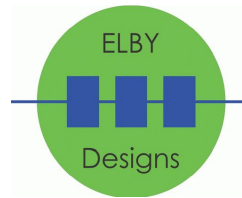

3 Therese Street
Bridport
TAS 7262
Australia

IMPORTANT NOTICE:
Information disclosed by this drawing is the property of ELBY Designs.
Duplication or manufacturing rights granted by written permission only.



CGS328 - Sequential Switch Power Supply

Size A4	FCSM No. 24/04/2022	DWG No. cgs328-power.schdoc	Rev V3.0
Scale	Laurie Biddulph		Sheet 6 of 6