

3 Therese Street
Bridport
TAS 7262
Australia

IMPORTANT NOTICE:
Information disclosed by this drawing is the property of ELBY Designs.
Duplication or manufacturing rights granted by written permission only.

CGS747 - Cynare Drum Simulator Block Diagram

Reproduced in collaboration with Ken Stone

Size A3	FCSM No. 22/07/2022	DWG No. cgs747-block.schdoc	Rev V2.2
Scale	Sheet Laurie Biddulph		Sheet 1 of 9

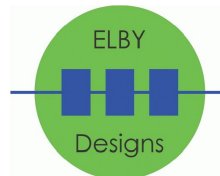
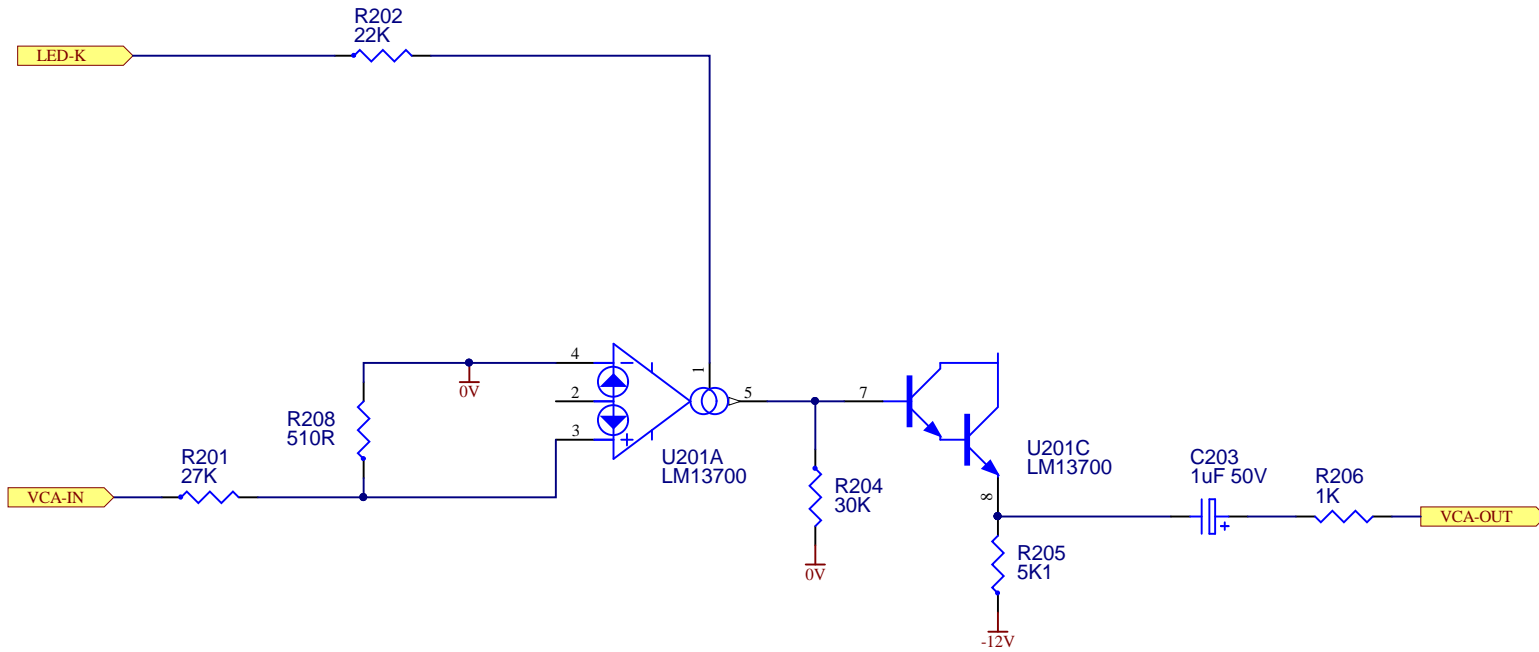

3 Therese Street
Bridport
TAS 7262
Australia

IMPORTANT NOTICE:

Information disclosed by this drawing is the property of ELBY Designs.
Duplication or manufacturing rights granted by written permission only.

**CGS747 - Cynare Drum Simulator
Voltage Controlled Amplifier**

Reproduced in collaboration with Ken Stone

Size A4	FCSM No. 22/07/2022	DWG No. cgs747-vca.schdoc	Rev V2.2
Scale	Laurie Biddulph		Sheet 2 of 9

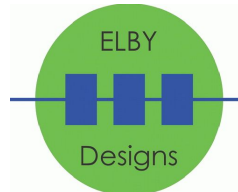
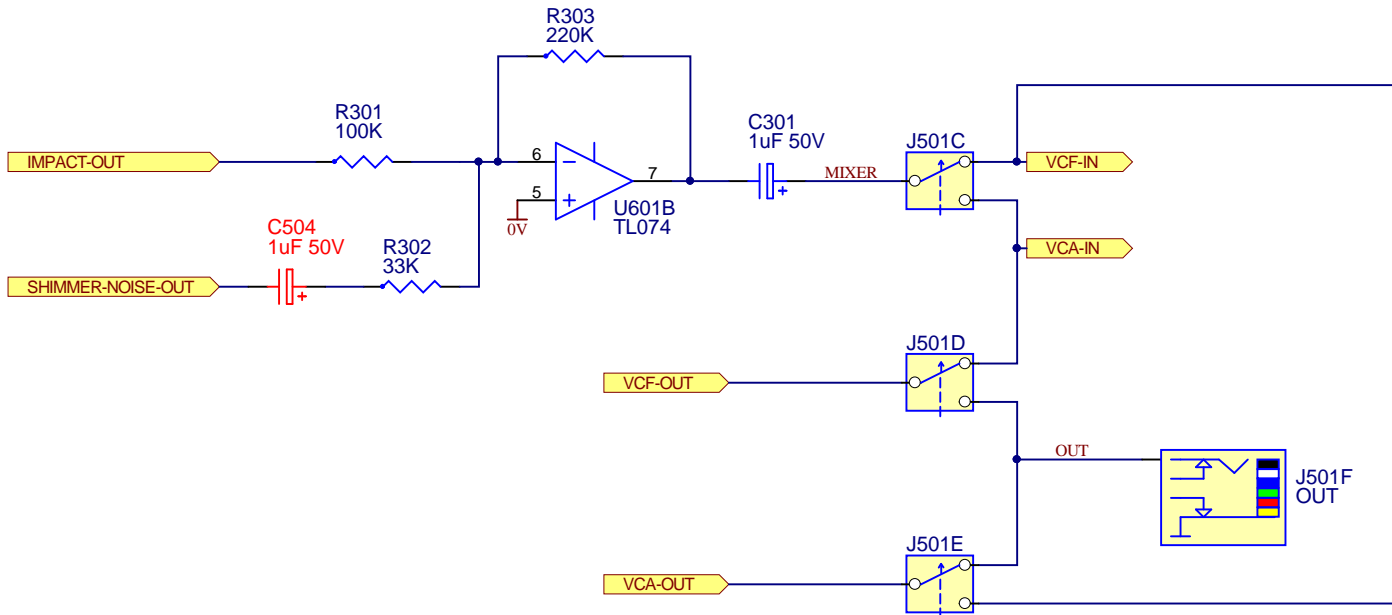

3 Therese Street
Bridport
TAS 7262
Australia

IMPORTANT NOTICE:

Information disclosed by this drawing is the property of ELBY Designs.
Duplication or manufacturing rights granted by written permission only.

CGS747 - Cynare Drum Simulator Mixer Stage

Reproduced in collaboration with Ken Stone

Size A4	FCSM No. 22/07/2022	DWG No. cgs747-mixer.schdoc	Rev V2.2
Scale	Laurie Biddulph		Sheet 3 of 9

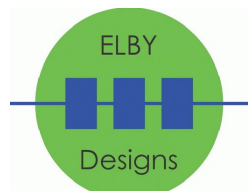
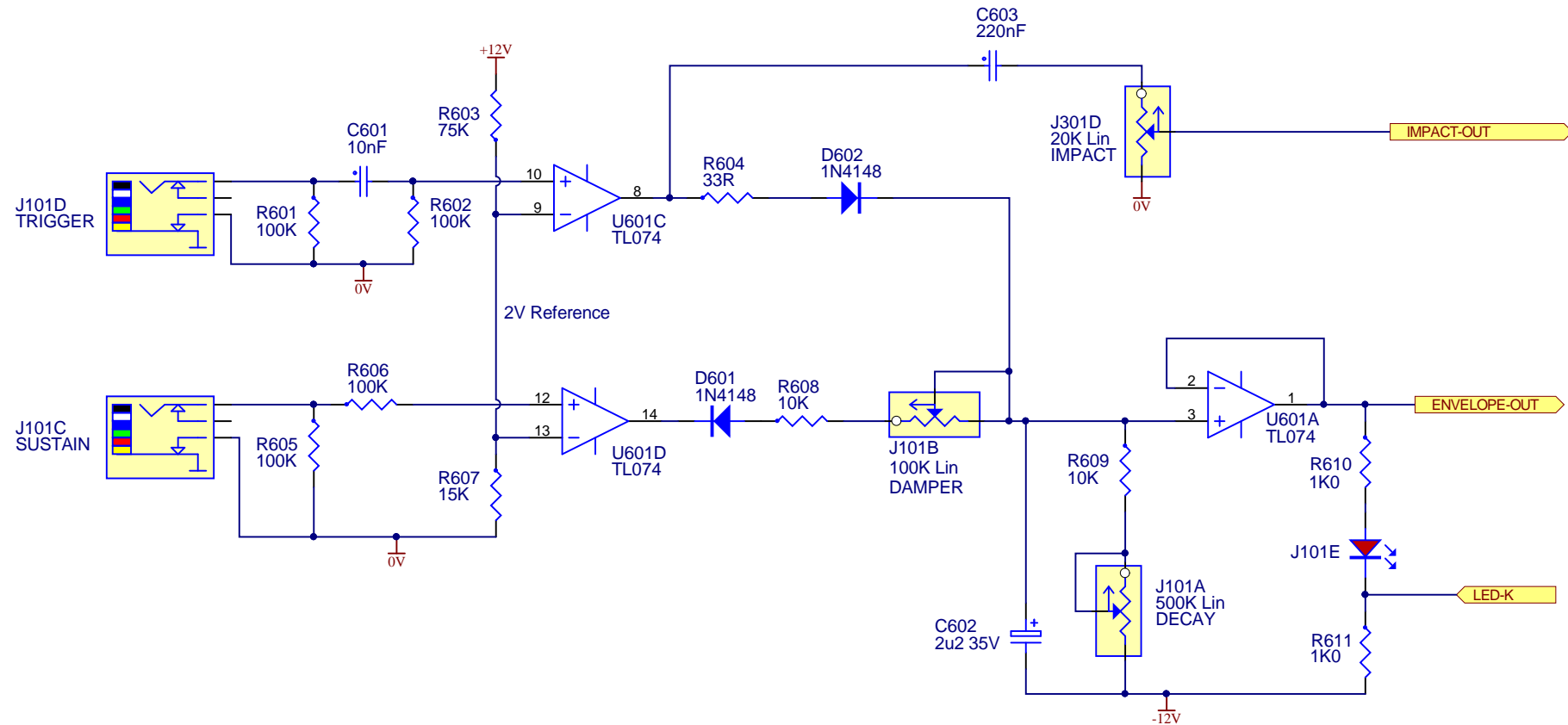

3 Therese Street
Bridport
TAS 7262
Australia

IMPORTANT NOTICE:
Information disclosed by this drawing is the property of ELBY Designs.
Duplication or manufacturing rights granted by written permission only.

CGS747 - Cynare Drum Simulator Envelope Generator

Reproduced in collaboration with Ken Stone

Size A4	FCSM No. 22/07/2022	DWG No. cgs747-envelope.schdoc	Rev V2.2
Scale	Laurie Biddulph	Sheet 4 of 9	

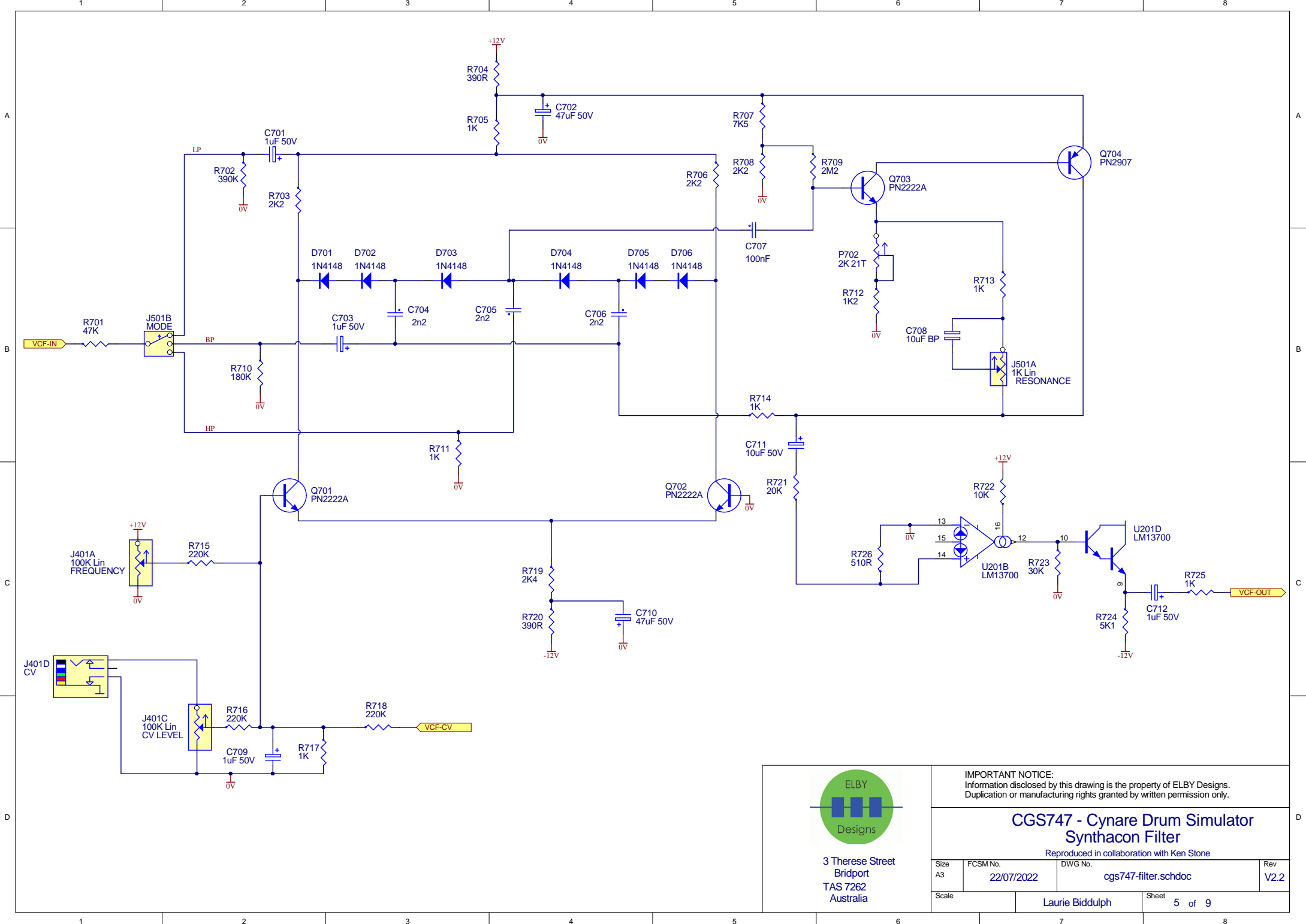

3 Therese Street
Bridport
TAS 7262
Australia

IMPORTANT NOTICE:
Information disclosed by this drawing is the property of ELBY Designs.
Duplication or manufacturing rights granted by written permission only.

CGS747 - Cynare Drum Simulator Synthacon Filter

Reproduced in collaboration with Ken Stone

Size A3	FCSM No. 22/07/2022	DWG No. cgs747-filter.schdoc	Rev V2.2
Scale	Laurie Biddulph		Sheet 5 of 9

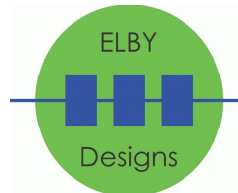
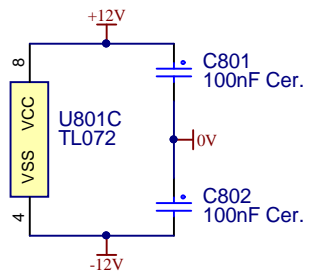
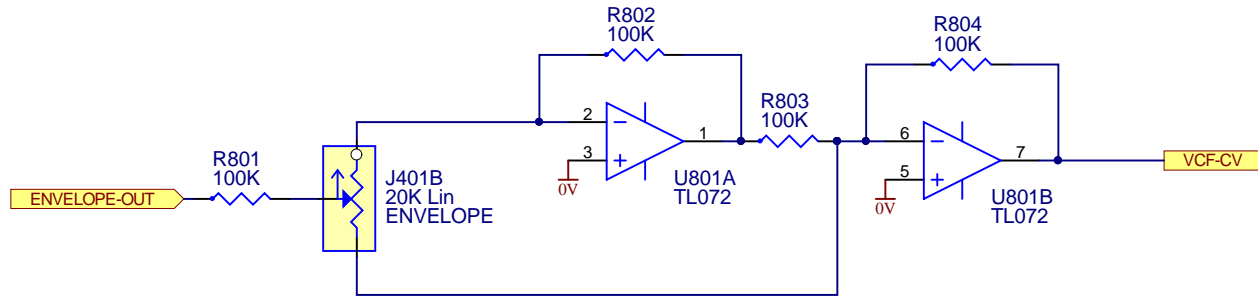

3 Therese Street
Bridport
TAS 7262
Australia

IMPORTANT NOTICE:
Information disclosed by this drawing is the property of ELBY Designs.
Duplication or manufacturing rights granted by written permission only.

CGS747 - Cynare Drum Simulator Processor Circuit

Reproduced in collaboration with Ken Stone

Size A4	FCSM No. 22/07/2022	DWG No. cgs747-processor.schdoc	Rev V2.2
Scale		Laurie Biddulph	Sheet 6 of 9

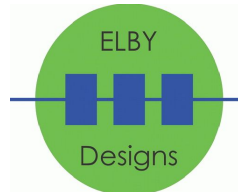
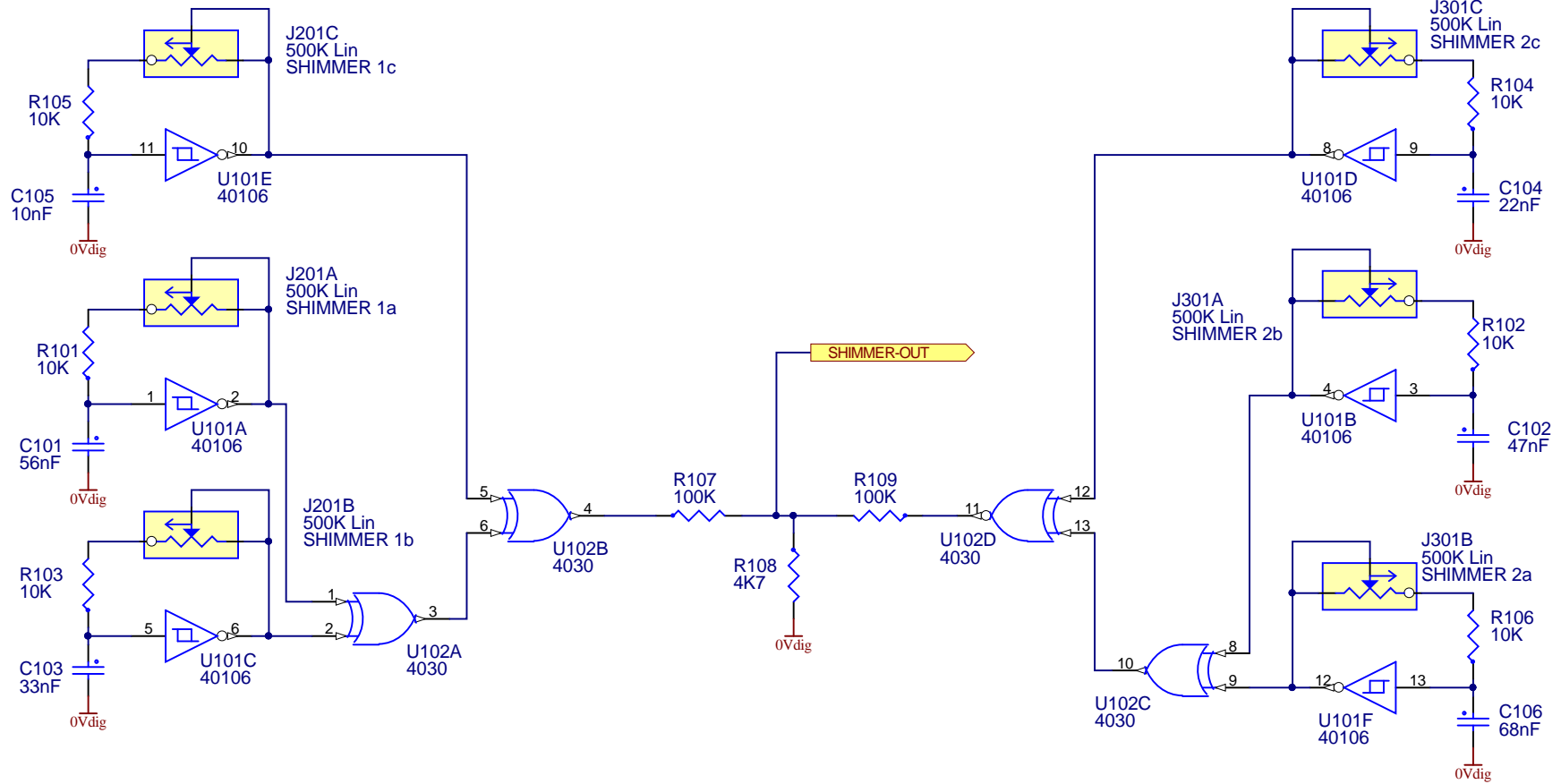

3 Therese Street
Bridport
TAS 7262
Australia

IMPORTANT NOTICE:
Information disclosed by this drawing is the property of ELBY Designs.
Duplication or manufacturing rights granted by written permission only.

CGS747 - Cynare Drum Simulator Shimmer Circuit

Reproduced in collaboration with Ken Stone

Size A4	FCSM No. 22/07/2022	DWG No. cgs747-shimmer.SCHDOC	Rev V2.2
Scale	Laurie Biddulph		Sheet 7 of 9

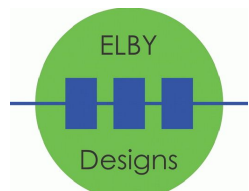
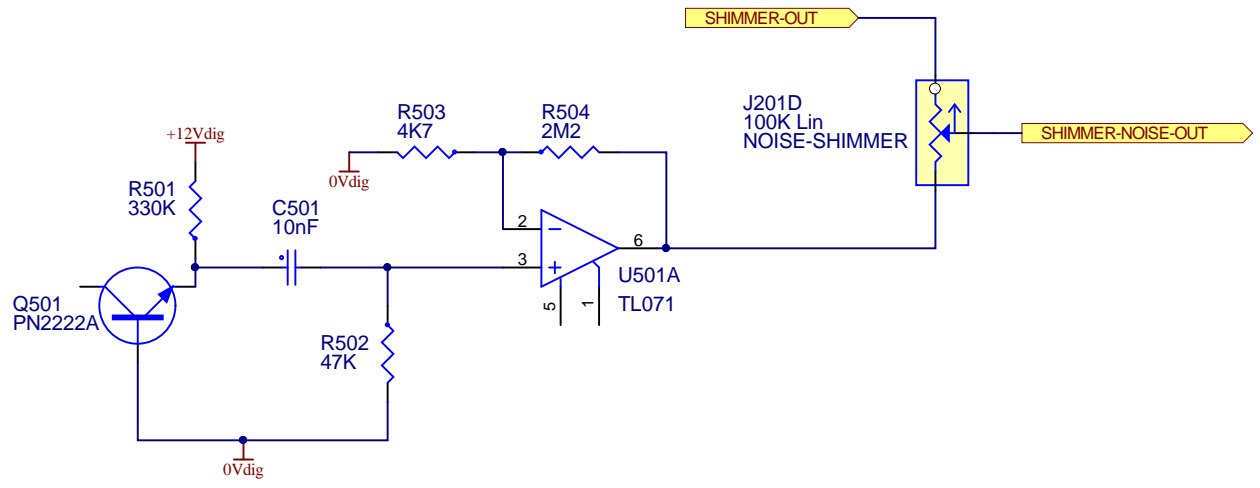

3 Therese Street
Bridport
TAS 7262
Australia

IMPORTANT NOTICE:
Information disclosed by this drawing is the property of ELBY Designs.
Duplication or manufacturing rights granted by written permission only.

CGS747 - Cynare Drum Simulator Noise Generator

Reproduced in collaboration with Ken Stone

Size A4	FCSM No. 22/07/2022	DWG No. cgs747-noise.SCHDOC	Rev V2.2
Scale		Laurie Biddulph	Sheet 8 of 9

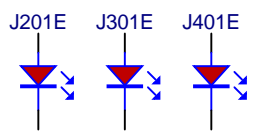
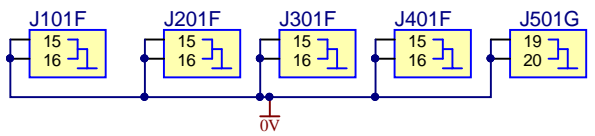
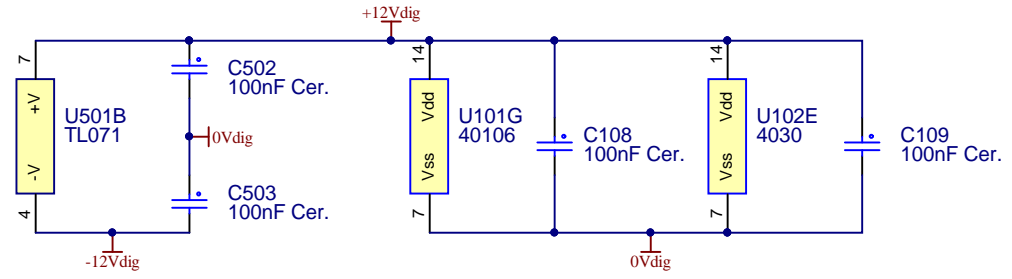
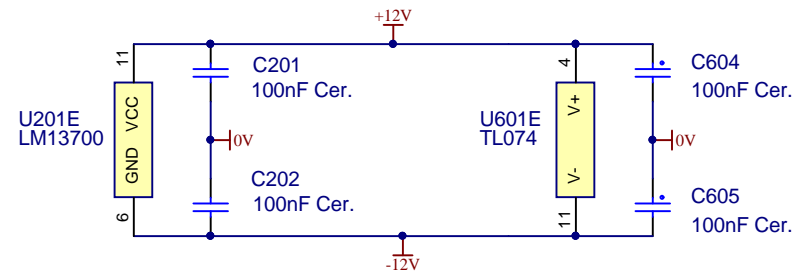
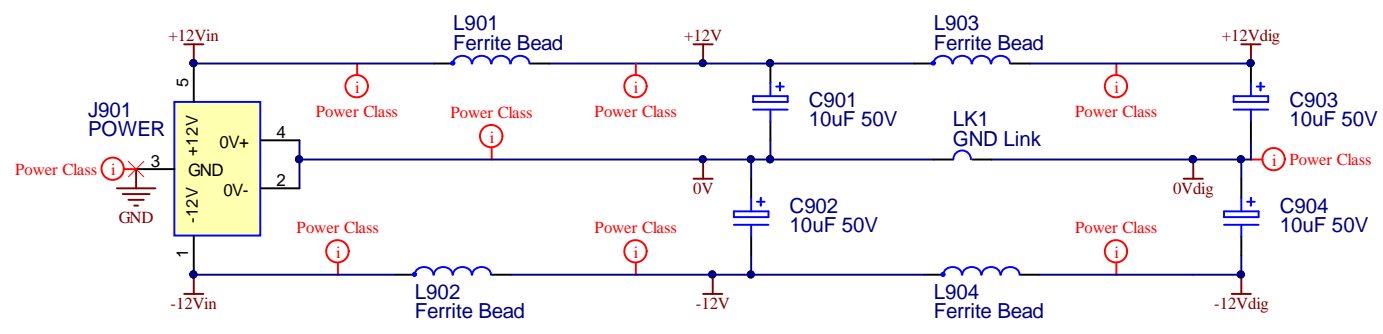

ELBY
Designs

3 Therese Street
Bridport
TAS 7262
Australia

IMPORTANT NOTICE:
Information disclosed by this drawing is the property of ELBY Designs. Duplication or manufacturing rights granted by written permission only.

CGS747 - Cynare Drum Simulator Power Supply

Reproduced in collaboration with Ken Stone

Size A4	FCSM No. 22/07/2022	DWG No. cgs747-power.schdoc	Rev V2.2
Scale		Laurie Biddulph	Sheet 9 of 9